

TOWN OF CHESHIRE
DEPARTMENT OF PUBLIC WORKS/ENGINEERING
84 SOUTH MAIN STREET, CHESHIRE, CONNECTICUT 06410
Telephone (203) 271-6650 Fax (203) 271-6659

CHESHIRE PUBLIC LIBRARY PARKING LOT IMPROVEMENTS

RFP #2223-31

[ADDENDUM NO. 1](#)

April 4, 2023

NOTICE TO ALL BIDDERS:

The attention of all bidders submitting proposals for this RFP is called to the following Addenda to the specifications and plans. The items set forth herein, whether of omission, addition or substitution are to be included in, and form part of the specifications and plans of the above-named project for bids to be received as advertised.

The following clarifications, modifications, deletions and additions are hereby incorporated into and become part of the Contract Documents.

RESPONSES TO QUESTIONS RECEIVED:

Question 1: Drawing shows extruded concrete curb on the reclaimed base, is that what you want?

Response 1: **The extruded concrete curb is to be placed on top of the pavement binder course. Corrected detail is attached.**

Question 2: Do you want the extruded concrete curb on the binder?

Response 2: **The extruded concrete curb is to be placed on top of the pavement binder course. Corrected detail is attached.**

Question 3: Do you want the extruded concrete curb on the top course?

Response 3: **The extruded concrete curb is to be placed on top of the pavement binder course. Corrected detail is attached.**

Question 4: Is the Island extruded concrete curb?

Response 4: **Yes.**

Question 5: Is the curb coming in the main entrance on the right-hand side extruded concrete curb or typical poured in place / integral? (where it meets walk and type B curb ramp)?

Response 5: **The curbing along the rear (main) entrance is to be an integral type (poured-in-place).**

Question 6: What testing is the Town paying for?

Response 6: The Town shall perform all in place soils and bituminous density tests as deemed necessary to ensure proper soils and bituminous pavement compaction.

Question 7: Is Building permit fees waived or by the contractor?

Response 7: Permitting by the Building Department is not anticipated at this time.

Question 8: Is the project requires SBE/MBE percentage? Please provide the percentage if there is?

Response 8: No.

Question 9: Are utilities (electric and water) available for construction use free of charge?

Response 9: No.

Question 10: The Extruded Curbing on the plan details says a 9" curb on gravel base with a 6" reveal, but on the description page line R says 6" extruded curb?

Response 10: The extruded concrete curb is to be placed on top of the pavement binder course with a 6" reveal. Corrected detail is attached.

Question 11: New light fixtures and poles are provided by the Town of Cheshire or the contractor?

Response 11: Light fixtures and poles to be provided by the Contractor.

ATTACHMENTS:

1. Corrected Extruded Concrete Curb detail.

END OF ADDENDUM NO. 1

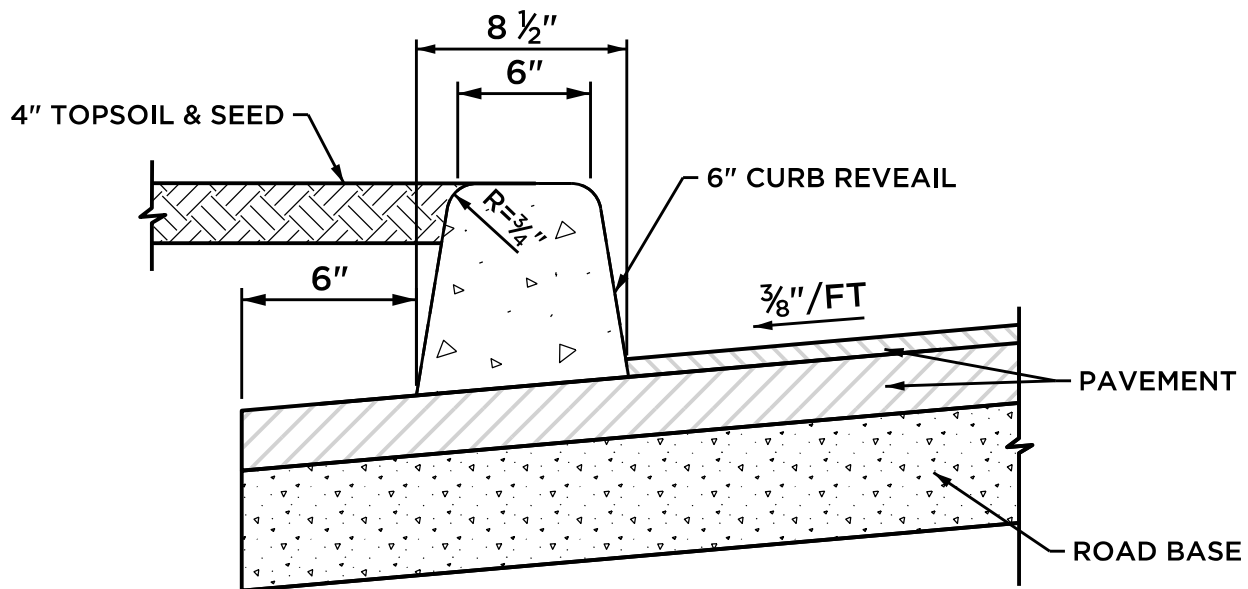

NOTES:

1. CONCRETE TO BE CLASS F (4000 PSI)
2. ONE HALF INCH (1/2") EXPANSION JOINT AT INTERVALS NOT TO EXCEED 20'. EXPANSION JOINT TO RUN TO THE FACE OF CURB.
3. CURBING SHALL BE MACHINE EXTRUDED.
4. SURFACE ON WHICH CURBING IS PLACED SHALL BE CLEAN.
5. CURBING TO BE LAID ON TOP OF BINDER COURSE.

NOT TO SCALE